

# STOP GLOBE VALVE - ANGULAR WITH BELLOWS TYPE 222M

## CHARACTERISTIC:

- Diameter - 15 - 300 mm;
- Pressure - 40 bar (flanges may be drilled for PN 6, 10, 16, 25 bar);
- Temperature - up to 530°C (with PTFE sealing up to ≤ 200°C);
- Medium - water, steam and other non-toxic, non aggressive liquid and gas media and engine fuel, sea water.

## VERSIONS:

type / ends / body material / disc and disc ring / others

Example: 222M / --- / --- / --- / ---

Example: 222M / S / U / R / WM

Ends	Sign	Body material	Sign	Disc and disc ring	Sign	Others	Sign
Standard - flanged	---	(P250GH) C 22.8 or GP240GH	---	Standard	---	Sea version	WM
Butt weld ends	S			Throttle plug	R		
Socket weld	SW	16Mo3 or G20Mo5	U	Throttle plug	RR		
Threaded	G			Throttle plug	Q		
				PTFE ring	P		
				NBR ring	N		
				STELLIT ring	L		

## APPLICATION:

Stop globe valve is designed to open and stop the flow. The valve is not supposed to be used as a regulating device. For regulation the version „R” with throttling plug should be applied.

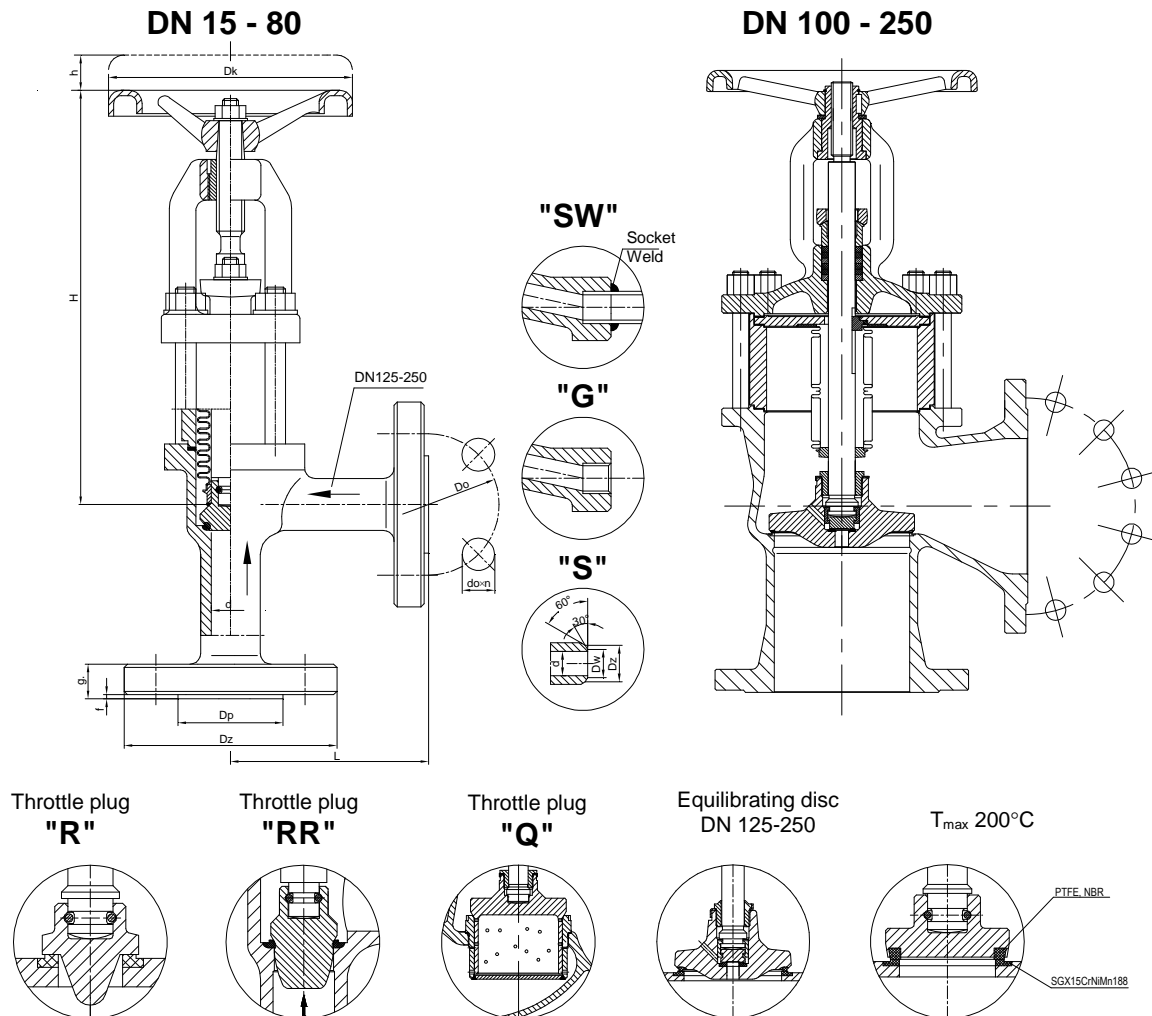

# WK



**FABRYKA ARMATURY PRZEMYSŁOWEJ**

**„WAKMET” spółka jawna**

Kaczmarek, Krzywdziński, Wachowski, Wilczyński

**Bodzanów 75 48-340 GŁUCHOŁAZY 1**

tel.+48(077) 439-40-20, fax +48(077) 439-18-72

e-mail: wakmet@wakmet.com.pl

http: www.wakmet.com.pl

## MATERIALS:

Versions	Standard	U	Standard	U
	T <sub>MAX</sub> 450°C	T <sub>MAX</sub> 530°C	T <sub>MAX</sub> 450°C	T <sub>MAX</sub> 500°C
Parts	DN 15 - 80		DN 100 - 250	
Body , bonnet	(P250GH) C22.8 (1.0460)	16Mo3 (1.5415)	GP240GH (1.0619)	G20Mo5 (1.5419)
Seat ring DN15-25	X17CrNi16-2			
Seat ring	G 18 8 Mn (1.4370) or Stellite , or CW306G			
Disc	X30Cr13 (1.4028) , X17CrNi16-2 (1.4057) , P245GH (1.0352) , CW306G			
Disc ring	G 18 8 Mn (1.4370) or Stellite , CW306G , PTFE , NBR			
Stem	X17CrNi16-2 (1.4057) , X20Cr13 (1.4021) , BT9 , CW306G			
Bellows	X6CrNiTi18-10 (1.4541)			
Packing rings, gasket	Grafit			
Wheel	Cast iron			

Special materials on request; modifications reserved.

## DIMENSIONS:

DN	Standard - flanged																	With butt weld ends		
	PN 40												PN 16					Dz	Dw	Weight
	Dz	Dp	Do	do	n	L	g.	f	H	h	Dk	Weight	Dz	Dp	Do	do	n			
15	95	45	65	14	4	90	16	2	153	15	120	4,30	95	45	65	14	4	22	17	2,90
20	105	58	75	14	4	95	18	2	153	15	120	4,80	105	58	75	14	4	28	22	2,90
25	115	68	85	14	4	100	18	2	153	15	120	8,50	115	68	85	14	4	35	28,5	2,90
32	140	78	100	18	4	105	18	2	240	17	160	9,10	140	78	100	18	4	44	37	5,10
40	150	88	110	18	4	115	18	3	250	22	160	12,30	150	88	110	18	4	50	43	5,50
50	165	102	125	18	4	125	20	3	255	26	160	24,00	165	102	125	18	4	62	54	8,20
65	185	122	145	18	8	145	22	3	290	30	200	31,50	185	122	145	18	4	77	69	19,30
80	200	138	160	18	8	155	24	3	320	36	250	53,00	200	138	160	18	8	91	81	26,50
100	235	162	190	22	8	175	24	3	360	50	320	63,00	220	158	180	18	8	117	104	46,80
125	270	188	220	26	8	200	26	3	390	58	280	84,00	250	184	210	18	8	144	130,5	57,30
150	300	218	250	26	8	225	28	3	440	70	320	110,00	285	212	240	22	8	172	156,5	79,00
200	375	285	320	30	12	275	34	3	515	92	400	175,00	340	268	295	22	12	223	204,5	132,00
250	450	345	385	33	12	325	38	3	590	130	400	267,00	405	320	355	26	12	278	256,5	220,00

Dimensions in mm; modifications reserved.

## TECHNICAL DATA:

Body material	PN	Maximal working pressure at working temperature																
		20°C	100°C	150°C	200°C	250°C	300°C	350°C	400°C	450°C	480°C	500°C	510°C	520°C	530°C	540°C	550°C	560°C
(P250GH)C 22.8 (1.0460)	40	40,0	40,0	40,0	36,2	32,4	28,6	24,8	20,9	13,1	-	-	-	-	-	-	-	-
16Mo3 (1.5415)	40	40,0	40,0	40,0	40,0	39,0	34,3	32,4	30,5	29,5	22,4	17,7	14,5	11,2	9,0	-	-	-
GP240GH (1.0619)	40	40,0	31,6	28,9	26,3	24,1	20,3	25,7	19,5	12,5	-	-	-	-	-	-	-	-
G20Mo5 (1.5419)	40	40,0	33,2	30,9	28,6	26,7	24,8	23,3	22,5	21,8	16,4	12,8	-	-	-	-	-	-

## MOUNTING AND OPERATING:

*The valve can only be mounted and operated by skilled, properly trained and qualified personnel. Incorrect assembly or operation of the valve may have substantial impact on the entire system such as fluid leakage, reduction in system's function etc.*

Before a valve is installed the pipeline must be clean from any mechanical impurities. The compatibility of critical parameters of the flow must be checked with the parameters of the valve. Stop globe valve can be mounted to a pipe-line in any position. The direction of flow should only comply with the arrow marked on the body. The valve should be operated strictly with its assign. In order to provide valve's reliability the following suggestions must be observed:

- medium flowing through the valve is supposed to be clean out of any mechanical impurities;
- the valve must be protected from any mechanical damages during its work;
- nominal parameters marked on the valve must be observed.